



6455 S. Dean Martin Drive, Suite C.
 Las Vegas, Nevada 89118
 Phone: (702) 309-8326 * Fax: (702) 309-8328
 Email: orders@exposervicesdesk.com
 Order Online: www.exposervicesdesk.com

EVENT NAME: PACVET 2026		EVENT DATES: JUNE 19-20, 2026		LOCATION: SCUSS	
EXHIBITING COMPANY NAME:				BOOTH NUMBER:	
BILLING NAME (if different from above):			Deadline for Advance Rate: JUNE 5, 2026		
BILLING ADDRESS:					
CITY:		STATE:		ZIP CODE:	
TELEPHONE:			FAX:		
CARDHOLDER SIGNATURE:			CARDHOLDER NAME (PRINT):		
			ORDERED BY:		
EMAIL (REQUIRED FOR RECEIPT):					
WE ACCEPT: VISA / MASTERCARD / AMERICAN EXPRESS		CVV:		EXPIRATION DATE:	
CC NUMBER HERE:					

CHARGES WILL APPEAR ON STATEMENT AS "TEAM CO"

Qty.	Description	Advance Rate	Regular Rate	Total	TERMS & CONDITIONS
120V LIGHTING & UTILITY OUTLETS					Convention Technical Services (CTS) is not responsible for voltage fluctuation or power failure due to temporary conditions including but not limited to losses due to utility company failure, permanent power distribution failure, power failure caused by vandalism, faulty exhibitor equipment or overloads caused by exhibitor. For your protection you should install a surge protector on your computer(s). All electrical installations and connections to all electrical service should be made by a CTS technician. CTS will not be responsible for any damage or loss to any equipment component, computer hardware or software, and/or any damage or injury to any person caused by the installation, connection, or plugging in of any electrical outlet by persons other than a CTS technician.
	500 Watt or 5 Amps	179.00	269.00		
	1000 Watt or 10 Amps	317.00	475.00		
	2000 Watt or 20 Amps	423.00	634.00		
	30 Amps (Labor Req.)	CALL FOR QUOTE			
208V 1 PHASE MOTOR & EQUIPMENT OUTLETS					Important: -To receive advance show prices, we must receive your order, along with payment, in full , within fourteen (14) days prior to show opening. All others will be charged at regular rate. -Any connection required beyond the finished outlet will be charged for time and materials. If you have special needs, please contact us in advance of move-in. -Power sharing <u>is not</u> permitted between exhibitors. -Exhibitors are not permitted to use power unless ordered. Exhibitors found using outlets without an order will be subject to the regular rate for outlets used. -Electricity will be turned on within 30 minutes of show opening and off within 30 minutes after show closing. -Dedicated circuits and 24 hour services will be double the listed price and require a 20 amp outlet. Please double rates. Use * to indicate 24-Hr Outlets. -Refunds will not be authorized if service is installed. Outlet Location & Distribution: -Island Booths: All electrical outlets for island booths will require labor and materials. Distribution and connections of all outlets are chargeable on a time and materials basis. Please complete a utility diagram with main drop, orientation and dimensions. -Inline & Peninsula Booths: All power is delivered to the back line of the booth at no extra cost. Labor only applies to additional distribution, on a time and materials basis. Please complete a utility diagram for outlets off the back line of the booth. -208V & Higher: Electrical labor required. -Unless a scaled floor plan is provided, electrical will be installed as CTS deems necessary or not at all until direction is given. Jurisdiction: -All under carpet distribution. -All motor & equipment hook-ups requiring wiring connections. -Labor is required to inspect equipment pre-wired to plug into our system. -Installation and/or repair of electrical fixtures. -Installation of electrical motors and electrical apparatus to be energized.
	20 Amp	797.00	1195.50		
	30 Amp	953.50	1430.00		
	60 Amp	1249.50	1874.00		
	100 Amp	1642.50	2464.00		
208V 3 PHASE MOTOR & EQUIPMENT OUTLETS					Island Booths: All electrical outlets for island booths will require labor and materials. Distribution and connections of all outlets are chargeable on a time and materials basis. Please complete a utility diagram with main drop, orientation and dimensions. Inline & Peninsula Booths: All power is delivered to the back line of the booth at no extra cost. Labor only applies to additional distribution, on a time and materials basis. Please complete a utility diagram for outlets off the back line of the booth. 208V & Higher: Electrical labor required. -Unless a scaled floor plan is provided, electrical will be installed as CTS deems necessary or not at all until direction is given. Jurisdiction: -All under carpet distribution. -All motor & equipment hook-ups requiring wiring connections. -Labor is required to inspect equipment pre-wired to plug into our system. -Installation and/or repair of electrical fixtures. -Installation of electrical motors and electrical apparatus to be energized.
	20 Amp	1063.00	1595.00		
	30 Amp	1270.00	1905.50		
	60 Amp	1665.00	2498.00		
	100 Amp	2189.00	3283.50		
	200 Amp	3134.00	4701.00		
TRANSFORMER(S) TO BOOST 208V TO 230V					Island Booths: All electrical outlets for island booths will require labor and materials. Distribution and connections of all outlets are chargeable on a time and materials basis. Please complete a utility diagram with main drop, orientation and dimensions. Inline & Peninsula Booths: All power is delivered to the back line of the booth at no extra cost. Labor only applies to additional distribution, on a time and materials basis. Please complete a utility diagram for outlets off the back line of the booth. 208V & Higher: Electrical labor required. -Unless a scaled floor plan is provided, electrical will be installed as CTS deems necessary or not at all until direction is given. Jurisdiction: -All under carpet distribution. -All motor & equipment hook-ups requiring wiring connections. -Labor is required to inspect equipment pre-wired to plug into our system. -Installation and/or repair of electrical fixtures. -Installation of electrical motors and electrical apparatus to be energized.
Total Amps:		X \$19.00 / AMP	=		
480V & ALL OTHER VOLTAGES PLEASE CALL FOR ESTIMATE					
LIFT					
1 HOUR MINIMUM INSTALL & ½ HOUR MINIMUM DISMANTLE					
LIFT		ST	275.00		LABOR: ST \$155.00 – OT \$280.00
LIFT		OT	412.50		
FLOODLIGHTS & TRACK					Office Use Only
	150 Watt Flood Light	179.00	269.00		CTS does not determine the move-in and move-out schedule for any event. Hourly rates apply to actual dates and times of install & dismantle. ST – Labor after 8:00am and before 4:30pm, weekdays. OT – Labor before 8:00am and after 4:30pm, weekdays. Weekends & Holidays are also OT.
	Double 150 Watt Flood	297.50	446.50		
	*Overhead/Can/Leko	496.00	744.00		
Overhead light may require labor and lift to install. First focus included. Call for a quote. Lighting Layout Required for Overhead Lights					



6455 S. Dean Martin Dr., Suite C * Las Vegas, Nevada 89118
Telephone: (702) 309-8326

Sample Layouts

Island Booth: Electrical layouts are required for all island booths.

Standard Location:

There is no such thing as a standard location in an island booth. There will be labor and material required to install the outlet ordered. If a layout is not provided, we will place power at our discretion.

What should be on a completed floor plan:

1. Main drop or outlet location. Island booths do not have a back wall so the main location operates as the point which all other power will be distributed from. There can often be many cords or cables in this location so it is often best to be in a closet, under a table or a location out of site.
2. Location of all other outlets. This includes the dimensions where the outlets will be placed. Without dimensions, outlets are likely to end up in the wrong locations in the booth.
3. Power requirements in each location. This can be 500 Watts / 1000 Watts / 2000 Watts or even 10 Amp 208 volt 3 Phase
4. Booth Orientation. This is especially useful for island booths. It helps us understand which side is which in the booth.

Completed Layout:

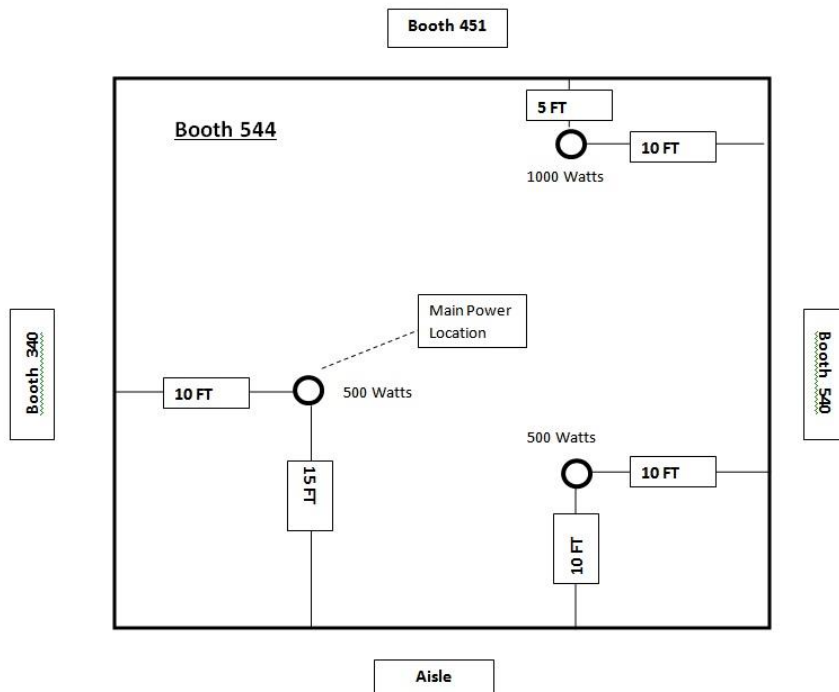

Inline or Peninsula Booths:

Layouts are only required when outlets are needed at any other location than the back of the booth.

Standard Location:

In Line

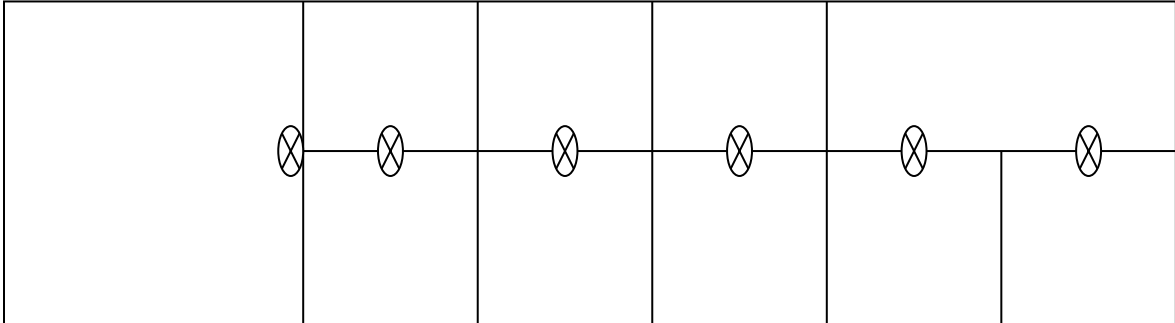

Completed Layout:

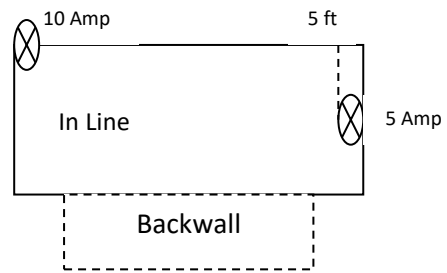
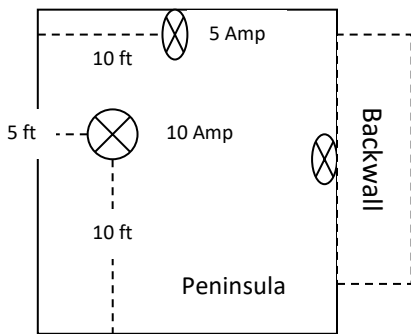

Thank you for your business!